

Manual de usuario e instalación

Unidades interiores de alta eficiencia

1.5 - 6 TR
Refrigerante R410-A

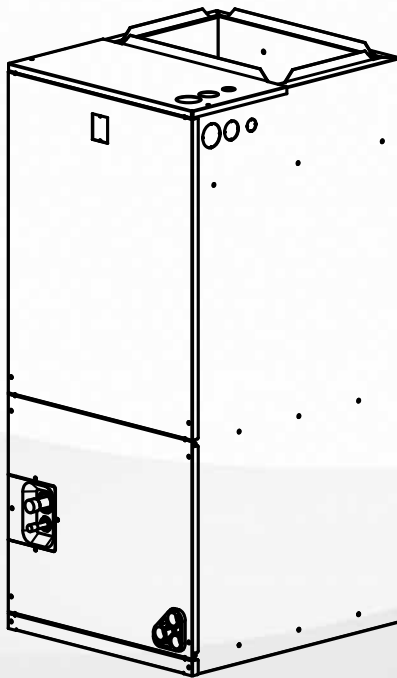

Modelos:

BMPE36CTL, BMPE60CTL & BMPE72CTL



**RECOGNIZE THIS SYMBOL AS AN INDICATION
OF IMPORTANT SAFETY
INFORMATIO**



These instructions are intended as an aid to qualified licensed service personnel for proper installation, adjustment and operation of this unit. Read these instructions thoroughly before attempting installation or operation. Failure to follow these instruction may result in improper installation,adjustment, service or maintenance possibly resulting in fire, electrical shock, property damage, personal injury or death.

DO NOT DESTROY THIS MANUAL

Please read carefully and keep in a safe place for future reference by a serviceman.

This document is customer property and is to remain with this unit.

These instructions do not cover all the different variations systems nor does it provide for every possible contingency to be met in connection with installtion.

All phases of this installation must comply with NATIONAL STATE AND LOCAL CODES.

If additional information is required please contact your local distributor.

Table of contents

1	Safety	04
2	General	08
	2.1 Unit dimensions	09
3	Applications	10
	3.1 Vertical upflow	10
	3.2 Vertical downflow	10
	3.3 Horizontal	12
	3.4 Installation in an unconditioned space	13
4	Electrical wiring	14
	4.1 Power wiring	14
	4.2 Control wiring	14
	4.3 Grounding	15
	4.4 Electrical data	15
5	Airflow performance	16
6	Ductwork	18
7	Refrigerant connections	19
	7.1 Condensate drain tubing	19
8	Air filter (not factory-installed)	21
9	Filter installation dimensions	22
10	Wire diagram	23

1. Safety



This is a safety alert symbol. When you see this symbol on labels or in manuals, be alert to the potential for personal injury.



This is an attention alert symbol. When you see this symbol on labels or in manuals, be alert to the potential for personal injury.



Disconnect all power to unit before installing or servicing. More than one disconnect switch may be required to de-energize the equipment. Hazardous voltage can cause server personal injury or death.



If removal of the blower assembly is required, all disconnect switches supplying power to the equipment must be de-energized and locked (if not in sight of unit) so the field power wires can be safely removed from the blower assembly. Failure to do so can cause electrical shock resulting in personal injuring or death.



Because of possible damage to equipment or personal injury, installation, service, and maintenance should be performed by a trained, qualified service personnel. Consumer service is recommended only for filter cleaning / replacement. Never operate the unit with the access panels removed.



These instructions are intended as an aid to qualified, licensed service personnel for proper installation, adjustment and operation of this unit. Read these instructions thoroughly before attempting installation or operation.

failure to follow these instructions may result in improper installation, adjustment, service or maintenance possibly resulting in fire, electrical shock, property damage, personal injury or death.

 WARNING

Decide the correct way of conveying the equipment.

Try to transport this equipment with the original package.

If the air conditioner needs to be installed on a metal part of the building, electric insulation must be performed, and the installation must meet the relevant technical standards of electric devices.

The appliance shall not be installed in the laundry.

Before obtaining access to terminals, all supply circuits must be disconnected.

The appliance must be positioned so that the plug is accessible.

The enclosure of the appliance shall be marked by word, or by symbols, with the direction of the fluid flow.

The appliance shall be installed in accordance with national wiring regulations. If the supply cord is damaged, it must be replaced by the manufacture or its service agent or a similarly qualified person in order to avoid a hazard.

An all-pole disconnection switch having a contact separation of at least 3mm in all poles should be connected in fixed wiring.

The temperature of refrigerant circuit will be high, please keep the interconnection cable away from the copper tube.

This appliance can be used by children aged from 8 years and above and persons with reduced physical, sensory or mental capabilities or lack of experience and knowledge if they have been given supervision or instruction concerning use of the appliance in a safe way and understand the hazards involved. Children shall not play with the appliance. Cleaning and user maintenance shall not be made by children without supervision.

 CAUTION

Install the unit where the air inlet and air outlet are free from obstacles and strong wind.

Install the unit in a dry and well ventilated place.

Install the unit where the bearing surface is level and can bear weight of the unit, and is suitable for installing the unit horizontally without increasing noise or vibration.

Install the unit where the operation noise and the expelling of air do not affect neighbors.

Install the unit where no flammable gas is leaked.

Install the unit where it is convenient for pipe connection and electric connection.

CAUTION



DISPOSAL: Do not dispose this product as unsorted municipal waste. Collection of such waste separately for special treatment is necessary.

Do not dispose of electrical appliances as unsorted municipal waste, use separate collection facilities.

Contact you local government for information regarding the collection systems available. If electrical appliances are disposed of in landfills or dumps, hazardous substances can leak into the groundwater and get into the food chain, damaging your health and well-being.

WARNING

The unit must be permanently grounded. Failure to do so can result in electrical shock causing personal injury or death.

WARNING

PROPOSITION 65: This appliance contains fiberglass insulation. Respirable particles of fiberglass are known to State of California to cause cancer.

All manufacturer products meet current federal OSHA Guidelines for safety.

California Proposition 65 warnings are required for certain products, which are not covered by the OSHA standards.

California's Proposition 65 requires warnings for products sold in California that contain or produce any of over 600 listed chemicals known to the State of California to cause cancer or birth defects such as fiberglass insulation, lead in brass, and combustion products from natural gas.

All "new equipment" shipped for sale in California will have labels stating that the product contains and /or produces Proposition 65 chemicals. Although we have not changed our processes, having the same label on all our product facilitates manufacturing and shipping. We cannot always know "when, or if" products will be sold in the California market.

You may receive inquiries from customers about chemicals found in, or produced by, some of our heating and air-conditioning equipment, or found in natural gas used with some of our products. Listed below are those chemicals and substances commonly associated with similar equipment in our industry and other manufacturers.

Glass Wool (Fiberglass) Insulation
Carbon Monoxide (CO).
Formaldehyde
Benzene

More details are available at the websites for OSHA (Occupational Safety and Health Administration), at www.osha.gov and the State of California's OEHHA (Office of Environmental Health Hazard Assessment), at www.oehha.org. Consumer education is important since the chemicals and substances on the list are found in our daily lives. Most consumers are aware that products present safety and health risks, when improperly used, handled and maintained.

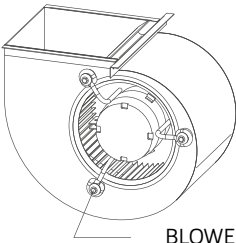

BLOWER MOTOR SHIPPING BOLT

Make sure the blower motor support is tight (3-motor mount bolts) then check to see if wheel is secured to motor shaft before operating unit.



The first 36 inches of supply air plenum and ductwork must be constructed of sheet metal as required by NFPA 90B. The supply air plenum or duct must have a solid sheet metal bottom directly under the unit with no openings, registers or flexible air ducts located in it. If flexible supply air ducts are used they may be located only in the vertical walls of rectangular plenum, a minimum of 6 inches from the solid bottom. Metal plenum or duct may be connected to the combustible floor base, if not, it must be connected to the unit supply duct exposed to the supply air opening from the downflow unit.

Exposing combustible (non-metal) material to the supply opening of a downflow unit can cause a fire resulting in property damage, personal injury or death.

Exception warning to downflow:

Installations on concrete floor slab with supply air plenum and ductwork completely encased must be not less than 2 inches of concrete (See NFPA 90A).

2. General

The unit can be positioned for bottom return air in the upflow position, left and right return in the horizontal position, top return in downflow position.

This Air Handler provides the flexibility for installation in any upflow or downflow horizontal application. The direct drive motors provides a selection of air volume to match any application. 3-Speed motors provide selections of air flow to meet desired applications. Top and side power and control wiring, accessible screw terminals for control wiring all combine to make the installation easy, and minimize installation cost. Please contact your local distributor. See fig.1.

For ensure the proper installation, Select the enough solid and level site.
Ensure enough space required for installation and maintenance.

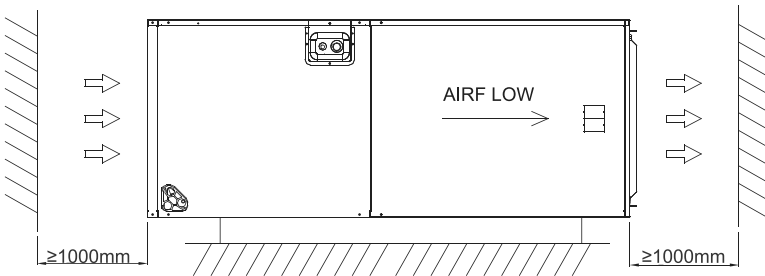

Top view of the outdoor unit (multiple units installed).

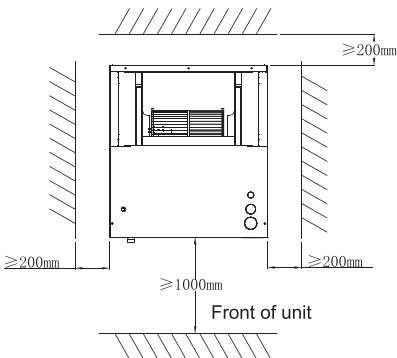

2.1 Unit dimensions

Note: 25° clearance is required in the front of the unit for filter and coil maintenance.

Electrical connections may exit top or either side.

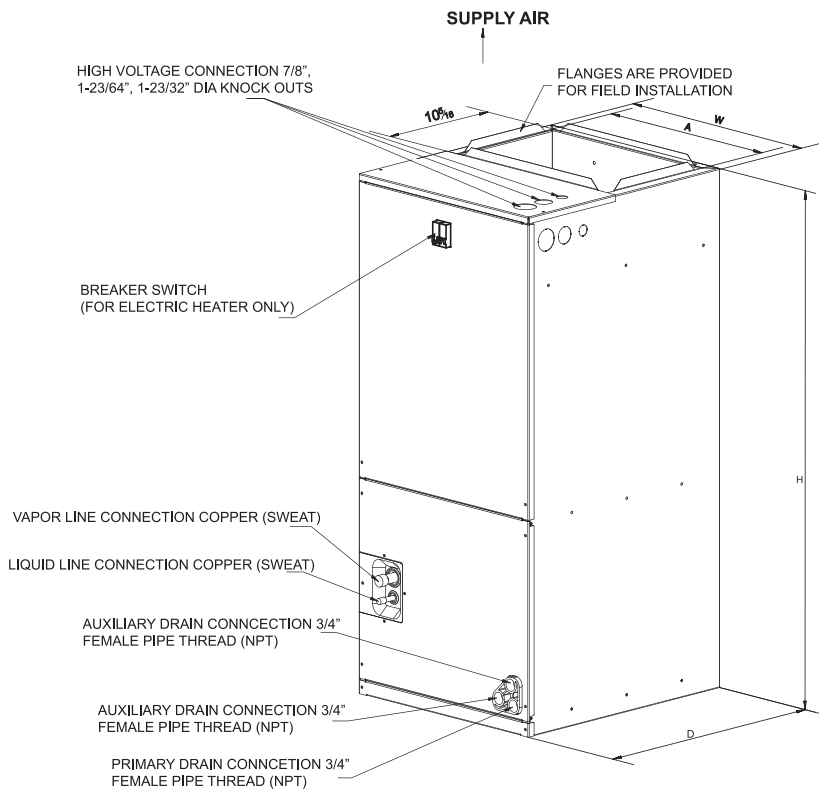

Fig 1 Dimensions

UPFLOW UNIT SHOWN;
UNIT MAY BE INSTALLED UPFLOW, DOWNFLOW,
HORIZONTAL RIGHT, OR LEFT AIR SUPPLY.

Dimension data

Dimensions inch [mm]					UNIT WEIGHT/ SHIPPING WEIGHT (LBS.[kg])
MODEL SIZE	UNIT HEIGHT "H" IN. [mm]	UNIT WIDTH "W" IN.[mm]	UNIT LENGHT "D" IN.[mm]	SUPPLY DUCT "A"	
24	41-3/8"[1050]	18-1/8"[460]	20-1/2"[520]	16"[406]	106/119 [48]/[54]
36	46-1/2"[1180]	19-5/8"[500]	20-5/8"[550]	18"[456]	141/156 [64]/[71]
60	54-1/2"[1385]	22"[560]	24"[610]	19-1/2"[496]	171/187 [78]/[85]
72	54-1/2"[1385]	22"[560]	24"[610]	19-1/2"[496]	171/187 [78]/[85]

3. Applications

3.1 Vertical Upflow

- Vertical Upflow configuration is the factory set on all models (see Fig 1).
- If a side return air opening is required, field fabricate a return air plenum with an opening large enough to supply unit and strong enough to support unit weight.
- If return air is to be ducted, install duct flush with floor. Use fireproof resilient gasket 1/8 to 1/4 in. thick between the ducts, unit and floor. Set unit on floor over opening.

IMPORTANT NOTE

Torque applied to drain connections should not exceed 15.ft.lbs.(see Fig.1&2)

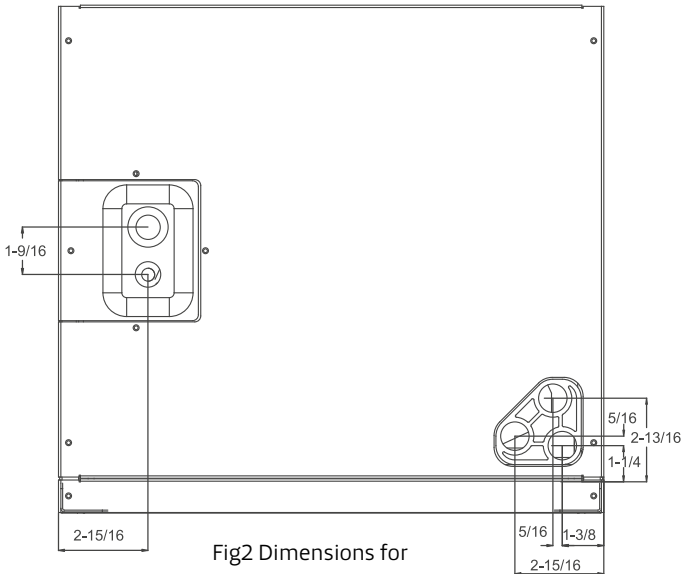

Fig2 Dimensions for front connect coil

3.2 Vertical Downflow

Conversion to Vertical Downflow: A vertical upflow unit may be converted to the vertical downflow on it. Remove the door and indoor coil and reinstall 180° from original position. See Fig. 2~3.

IMPORTANT

To comply with certification agencies and the National Electric Code for horizontal right application, the circuit breaker(s) on field-installed electric heater kits must be re-installed per procedure below so that the breaker switch “on” position and marking is up and, “off” position and marking is down.

- To rotate breaker(s): Rotate one breaker set (circuit) at a time starting with the one on the right. Loosen both lugs on the load side of the breaker. (Make sure that wires are identified and are reinstalled into proper breaker). Wires are bundles with wire ties, one bundle going to the right lug and one bundle going to the left lug.
- Using a screwdriver or pencil, lift blue plastic tab with hole away from breaker until breaker releases from mounting opening.
- With breaker held in hand, rotate breaker so that “on” position is up, “off” position is down with unit in planned vertical mounting position. Insert right wire bundle into top right breaker lug, ensuring all strands of all wires are inserted fully into lug, and no wire insulation is in lug.
- Tighten lug as tight as possible while holding circuit breaker. Check wires and make sure each wire is secure and none are loose. Repeat for left wire bundle in left top circuit breaker lug.
- Replace breaker by inserting breaker mounting tab opposite white pull tab in opening, hook mounting tab over edge in opening.
- With screwdriver or pencil, pull blue tab with hole away from breaker while setting that side of breaker into opening. When breaker is in place, release tab, locking circuit breaker into location in opening.
- Repeat above operation for remaining breaker(s) (if more than one is provided).
- Replace single point wiring jumper bar, if it is used, on line side of breaker and tighten securely.
- Double check wires and lugs to make sure all are secure and tight. Check to make sure unit wiring to circuit breaker load lugs match that shown on the unit wiring diagram.



When using the unit with electrical heater, the switch is used only for electrical heater on the front of panel.

3.3 Horizontal

Horizontal right is the default factory configuration for the units.

Horizontal left isn't the default factory configuration for the units.

Conversion to Horizontal: A vertical upflow unit may be converted to horizontal right by removing indoor coil assembly and reinstalling coil as shown for right hand air supply. And reinstall coil in unit as shown for right hand air supply.

- Rotate unit into the downflow position, with the coil compartment on top and the blower compartment on bottom. See Fig. 3.
- Reinstall the indoor coil 180° from original position. Ensure the retaining channel is fully engaged with the coil rail. See Fig. 3.
- Secondary drain pan kits are required when the unit is configured for the horizontal right position over a finished ceiling and/or living space.

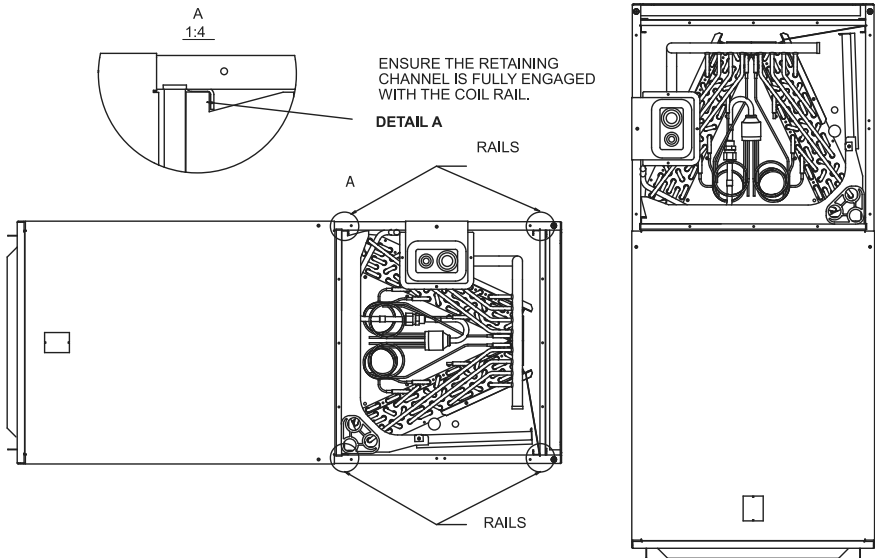
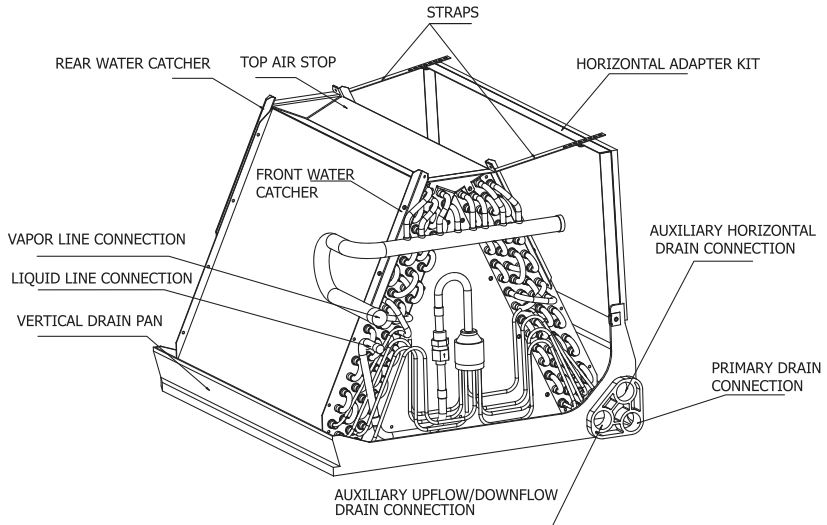

Fig3 Vertical downflow & horizontal left applications (lower front service panel removed “view”.)



The Max. resistant pressure of evaporator is up to 16MPa (2320PSI)

Fig4 Indoor coil and drain pan set-up

CAUTION

Horizontal units must be configured for right hand air supply or left hand air supply. Horizontal drain pan must be located under indoor coil. Failure to use the drain pan can result in property damage.

Conversion in Horizontal Direction: Horizontal left-hand supply can be changed to horizontal right-hand supply by removing the indoor coil and reinstalling 180° from original.

3.4 Installation in an unconditioned space

IMPORTANT

There are two pairs of coil rails in the air handler for default and counter flow application. If the air handler is installed in an unconditioned space, the two unused coil rails should be removed to minimize air handler surface sweating. The coil rails can be easily removed by taking off the 6 mounting screws from both sides of the cabinet.

4. Electrical wiring

Field wiring must comply with the National Electric Code (C.E.C. in Canada) and any applicable local ordinance.



Disconnect all power to unit before installing or servicing. More than one disconnect switch may be required to de-energize the equipment. Hazardous voltage can cause severe personal injury or death.

4.1 Power wiring

It is important that proper electrical power is available for connection to the unit model being installed. See the unit nameplate, wiring diagram and electrical data in the installation instructions. The power cord type designation is H05RN-R/H07RN-F.

- If required, install a branch circuit disconnect of adequate size, located within sight of, and readily accessible to the unit.

- **IMPORTANT**

After the Electric Heater is installed, units may be equipped with one, two, or three 30/60 amp. circuit breakers. These breaker(s) protect the internal wiring in the event of a short circuit and serve as a disconnect. Circuit breakers installed within the unit do not provide over-current protection of the supply wiring and therefore may be sized larger than the branch circuit protection.

- Supply circuit power wiring must be 75°C minimum copper conductors only. See Electrical Data In this section for ampacity, wire size and circuit protector requirement. Supply circuit protective devices may be either fuses or “HACR” type circuit breakers.
- Power wiring may be connected to either the right, left side or top. Three 7/8”, 1-3/8”, 1-3/4” dia. concentric knockouts are provided for connection of power wiring to unit.
- Power wiring is connected to the power terminal block in unit electric cabinet.

4.2 Control wiring

- **IMPORTANT**

Class 2 low voltage control wiring should not be run in conduit with main power wiring and must be separated from power wiring, unless class 1 wire of proper voltage rating is used.

- Low voltage control wiring should be 18 Awg. color-coded. For lengths longer than 100 ft., 16 Awg. wire should be used.

- Low voltage control connections are made to low voltage pigtailed extending from top of air handler (upflow position - see Figure 3). Connections for control wiring are made with wire nuts. Control wiring knockouts (5/8 and 7/8) are also provided on the right and left side of the unit for side connection.
- See wiring diagrams attached to indoor and outdoor sections to be connected.
- Make sure, after installation, separation of control wiring and power wiring has been maintained.

4.3 Grounding



The unit must be permanently grounded. Failure to do so can result in electrical shock causing personal injury or death.

- Grounding may be accomplished by grounding metal conduit when installed in accordance with electrical codes to the unit cabinet.
- Grounding may also be accomplished by attaching ground wire(s) to ground lug(s) provided in the unit wiring compartment.
- Ground lug(s) are located close to wire entrance on left side of unit (up-flow). Lug(s) may be moved to marked locations near wire entrance on right side of unit (upflow). If alternate location is more convenient.
- Use of multiple supply circuits require grounding of each circuit to lug(s) provided in unit.

4.4 Electrical data

NOMINAL COOLING	VOLTAGE	HERTZ	HP	RPM	SPEEDS	CIRCUIT AMPS	MIN. CIRCUIT AMPACITY	MAX. CIRCUIT VOLTAGE HERTZ
COOLING & HEATING	2	220-240	50	1/5	701	3	0.6	15(A)
	3	220-240	50	1/2	794	3	1.4	15(A)
	5	220-240	50	3/4	845	3	3.3	15(A)
	6	220-240	50	3/4	963	3	4.3	15(A)

5. Electrical wiring

Airflow performance data is based on cooling performance with a coil and no filter in place. Select performance table for appropriate unit size external static applied to unit allows operation within the minimum and maximum limits shown in table below for both cooling and electric heat operation.

NUMBER MODEL	MOTOR SPEED		CFM(Watts) External Static Pressure-Inches W.C.[kPa]									
			0 [0]	0.1 [.02]	0.16 [.04]	0.2 [.05]	0.3 [.07]	0.4 [.10]	0.5 [.12]	0.6 [.15]	0.7 [.17]	0.8 [.20]
24	LOW	CFM	695	658	618	606	560	490	392	242	-	-
		RPM	585	644	688	700	756	802	853	920	-	-
		Watts	153	146	139	137	130	120	109	92	-	-
		Amps	0.71	0.68	0.65	0.65	0.62	0.59	0.55	0.49	-	-
	MIDDLE	CFM	844	804	761	749	679	620	516	359	-	-
		RPM	680	723	759	768	813	858	900	950	-	-
		Watts	178	172	166	164	154	147	137	123	-	-
		Amps	0.81	0.78	0.76	0.75	0.71	0.69	0.64	0.59	-	-
	HIGH	CFM	935	901	853	839	760	691	583	456	169	-
		RPM	760	790	815	821	852	881	913	935	980	-
		Watts	220	214	208	205	194	184	171	159	133	-
		Amps	1.00	0.98	0.95	0.94	0.90	0.86	0.81	0.76	0.65	-
36	LOW	CFM	1261	1186	1114	1039	1022	919	798	527	280	-
		RPM	755	778	801	819	824	827	860	883	938	-
		Watts	290	277	264	254	251	236	216	182	157	-
		Amps	1.32	1.26	1.21	1.16	1.15	1.08	1.00	0.86	0.75	-
	MIDDLE	CFM	1394	1311	1229	1158	1142	1033	902	630	362	-
		RPM	815	833	851	865	869	887	905	923	950	-
		Watts	304	293	282	271	270	257	241	210	182	-
		Amps	1.39	1.33	1.28	1.23	1.22	1.17	1.10	0.95	0.84	-
	HIGH	CFM	1484	1403	1315	1245	1220	1123	988	685	420	243
		RPM	860	873	885	895	898	910	923	944	955	970
		Watts	352	341	328	319	315	303	228	250	222	208
		Amps	1.6	1.54	1.49	1.45	1.38	1.38	1.04	1.14	1.01	0.95

NUMBER MODEL	MOTOR SPEED		CFM(Watts) External Static Pressure-Inches W.C.[kPa]									
			0 [0]	0.1 [.02]	0.16 [.04]	0.2 [.05]	0.3 [.07]	0.4 [.10]	0.5 [.12]	0.6 [.15]	0.7 [.17]	0.8 [.20]
60	LOW	CFM	1571	1537	1493	1460	1451	1407	1351	1274	1208	1136
		RPM	742	784	819	850	859	890	926	962	994	1022
		Watts	639	630	616	610	608	596	571	568	553	538
		Amps	2.93	2.88	2.82	2.78	2.78	2.72	2.65	2.59	2.52	2.45
	MIDDLE	CFM	1696	1642	1593	1550	1545	1491	1440	1362	1301	1238
		RPM	796	835	869	893	900	932	961	996	1024	1053
		Watts	708	700	689	680	679	666	653	635	619	601
		Amps	3.26	3.2	3.14	3.11	3.1	3.04	2.99	2.9	2.82	2.74
	HIGH	CFM	1966	1941	1901	1865	1856	1810	1760	1707	1644	1571
		RPM	907	976	974	994	999	1025	1048	1070	1094	1117
		Watts	941	904	885	873	871	855	836	818	793	768
		Amps	4.33	4.12	4.02	3.98	3.97	3.9	3.81	3.72	3.62	3.49
72	LOW	CFM	1571	1537	1493	1460	1451	1407	1351	1274	1208	1136
		RPM	742	784	819	850	859	890	926	962	994	1022
		Watts	639	630	616	610	608	596	581	568	553	538
		Amps	2.93	2.88	2.82	2.78	2.78	2.72	2.65	2.59	2.52	2.45
	MIDDLE	CFM	1696	1642	1593	1550	1545	1491	1440	1362	1301	1238
		RPM	796	835	869	893	900	932	961	996	1024	1063
		Watts	708	700	689	680	679	666	653	635	619	601
		Amps	3.26	3.2	3.14	3.11	3.1	3.04	2.99	2.9	2.82	2.74
	HIGH	CFM	1966	1941	1901	1865	1856	1810	1760	1707	1644	1571
		RPM	907	976	974	994	999	1025	1048	1070	1094	1117
		Watts	941	904	885	873	871	855	836	818	793	768
		Amps	4.33	4.12	4.02	3.98	3.97	3.9	3.81	3.72	3.62	3.49

The air distribution system has the greatest effect on airflow. The duct system is totally controlled by the contractor. For this reason, the contractor should use only industry-recognized procedures.

Heat pump systems require a specified airflow. Each ton of cooling requires between 350 and 450 cubic feet of air per minute (CFM), or 400 CFM nominally.

Duct design and construction should be carefully done. System performance can be lowered dramatically through bad planning or workmanship.

Air supply diffusers must be selected and located carefully. They must be sized and positioned to deliver treated air along the perimeter of the space. If they are too small for their intended airflow, they become noisy. If they are not located properly, they cause drafts. Return air grilles must be properly sized to carry air back to the blower. If they are too small, they also cause noise. The installers should balance the air distribution system to ensure proper quiet airflow to all rooms in the home. This ensures a comfortable living space.

An air velocity meter or airflow hood can give a reading of system CFM.

6. Ductwork

Field ductwork must comply with the National Fire Protection Association NFPA 90A, NFPA 90B and any applicable local ordinance.



Do not, under any circumstances, connect return ductwork to any other heat producing device such as fireplace insert, stove, etc. Unauthorized use of such devices may result in fire, carbon monoxide poisoning, explosion, personal injury or property damage.

Sheet metal ductwork run in unconditioned spaces must be insulated and covered with a vapor barrier. Fibrous ductwork may be used if constructed and installed in accordance with SMACNA Construction Standard on Fibrous Glass Ducts. Ductwork must comply with National Fire Protection Association as tested by U/L Standard 181 for Class I Air Ducts. Check local codes for requirements on ductwork and insulation.

- Duct system must be designed within the range of external static pressure the unit is designed to operate against. It is important that the system airflow be adequate.

Make sure supply and return ductwork, grills, special filters, accessories, etc. are accounted for in total resistance. See airflow performance tables in this manual.

- Design the duct system in accordance with “ACCA” Manual “0” Design for Residential Winter and Summer Air Conditioning and Equipment Selection. Latest editions are available from: “ACCA” Air Conditioning Contractors of America, 1513 16th Street, N.W., Washington, D.C. 20036. If duct system incorporates flexible air duct, be sure pressure drop Information (straight length plus all turns) shown in “ACCA” Manual “D” is accounted for in system.
- Supply plenum is attached to the 3/4” duct flanges supplied with the unit. Attach flanges around the blower outlet.

IMPORTANT

If an elbow is included in the plenum close to the unit, it must not be smaller than the dimensions of the supply duct flange on the unit.

IMPORTANT

The front flange on the return duct if connected to the blower casing must not be screwed into the area where the power wiring is located. Drills or sharp screw points can damage insulation on wires located inside unit.

- Secure the supply and return ductwork to the unit flanges, using proper fasteners for the type of duct used and tape the duct-to-unit joint as required to prevent air leaks.

7. Refrigerant connections

Keep the coil connections sealed until refrigerant connections are made. See the Installation Instructions for the outdoor unit for details on line sizing, tubing installation, and charging information.

Coil is shipped with “No charge”. Evacuate the system before charging with refrigerant. Install refrigerant tubing so that it does not block service access to the front of the unit.

Nitrogen should flow through the refrigerant lines while brazing.

Use a brazing shield to protect the cabinet’s paint and a wet rag to protect the rubber grommet from being damaged by torch flames. After the refrigerant connections are made, seal the gap around the connections with pressure sensitive gasket.

7.1 Condensate drain tubing

Consult local codes for specific requirements.

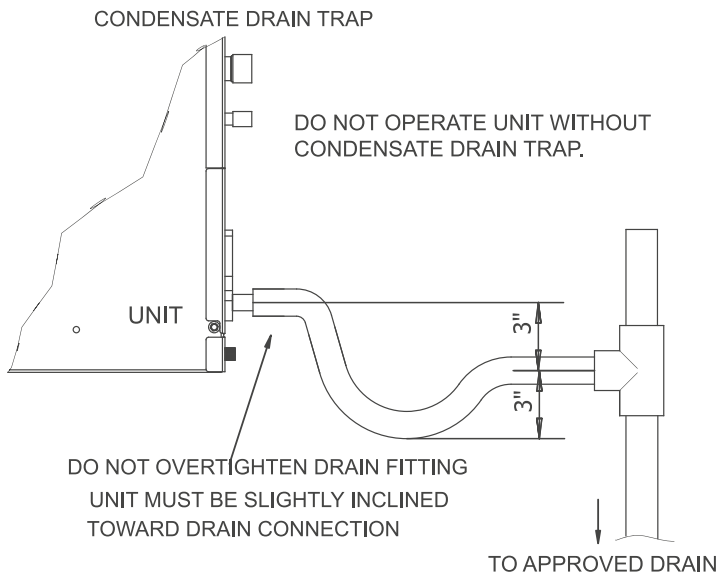

Fig5 Condensate drain trap

IMPORTANT

1. When making drain fitting connections to the drain pan, use a thin layer of Teflon paste, silicone or Teflon tape and install, hand tighten.
 2. When making drain fitting connections to drain pan, do not overtighten. Over tightening fittings can split pipe connections on the drain pan.
- Install drain lines so they do not block service access to front of the unit. Minimum clearance of 24 inches is required for filter, coil or blower removal and service access.
 - Make sure unit is level or pitched slightly toward primary drain connection so that water will drain completely from the pan. (See Fig. 5)
 - Do not reduce drain line size less than connection size provided on condensate drain pan.
 - All drain lines must be pitched downward away from the unit a minimum of 1/8" per foot of line to ensure proper drainage.
 - Do not connect condensate drain line to a closed or open sewer pipe. Run condensate to an open drain or run line to a safe outdoor area.

- The drain line should be insulated where necessary to prevent sweating and damage due to condensate forming on the outside surface of the line.
- Make provisions for disconnecting and cleaning of the primary drain line should it become necessary. Install a 3 inch trap in the primary drain line as close to the unit as possible. Make sure that the top of the trap is below connection to the drain pan to allow complete drainage of pan (See Fig. 5).
- Auxiliary drain line should be run to a place where it will be noticeable if it becomes operational. Homeowner should be warned that a problem exists if water should begin running from the auxiliary drain line.
- Plug the unused drain connection with the plugs provided in the parts bag, using a thin layer of teflon paste, silicone or teflon tape to form a water tight seal.
- Test condensate drain pan and drain line after installation is complete. Pour water into drain pan, enough to fill drain trap and line. Check to make sure drain pan is draining completely, no leaks are found in drain line fittings, and water is draining from the termination of the primary drain line.

8. Air filter (not factory-installed)

- External filter or other means of filtration is required. Units should be sized for a maximum of 300 feet/min. air velocity or what is recommended for the type filter installed.

Filter application and placement are critical to airflow, which may affect the heating and cooling system performance. Reduced airflow can shorten the life of the system's major components, such as motor, limits, elements, heat relays, evaporator coil or compressor. Consequently, we recommend that the return air duct system have only one filter location. For systems with a return air filter grill or multiple filter grills, can have a filter installed at each of the return air openings.

If adding high efficiency filters or electronic air filtration systems, it is very important that the air flow is not reduced. If air flow is reduced the overall performance and efficiency of the unit will be reduced. It is strongly recommended that a professional installation technician is contacted to ensure installation of these such filtration systems are installed correctly.

IMPORTANT

DO NOT DOUBLE FILTER THE RETURN AIR DUCT SYSTEM. DO NOT FILTER THE SUPPLY AIR DUCT SYSTEM. THIS WILL CHANGE THE PERFORMANCE OF THE UNIT AND REDUCE AIRFLOW .



Do not operate the system without filters. A portion of the dust entrained in the air may temporarily lodge in the duct runs and at the supply registers. Any circulated dust particles could be heated and charred by contact with the air handler elements. This residue could soil ceilings, walls, drapes, carpets and other articles in the house. Soot damage may occur with filters in place, when certain types of candles, oil lamps or standing pilots are burned.

9. Filter installation dimensions

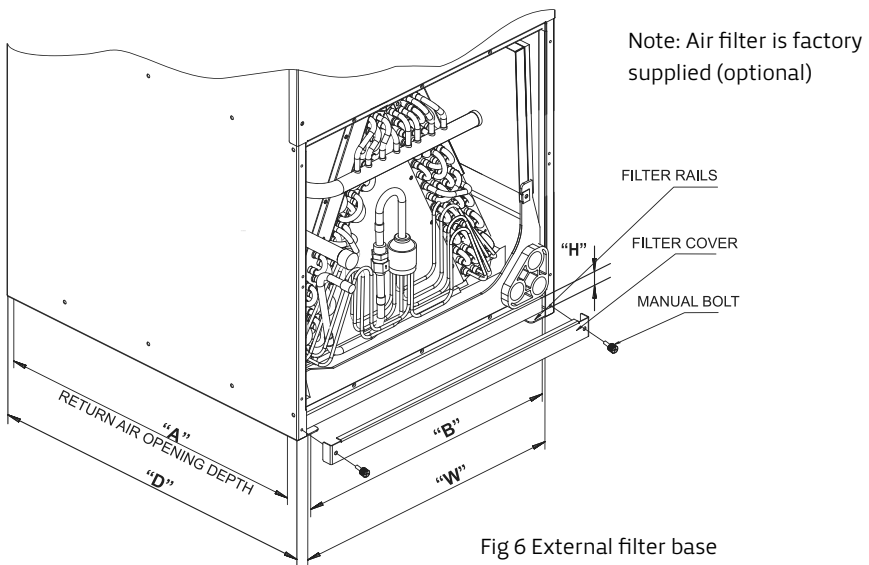

Fig 6 External filter base

Dimension data

MODEL SIZE	FILTER SIZE IN [mm]	“W” IN [mm]	“D” IN [mm]	“H” IN [mm]	Return width “A” IN	Return length MODEL “B” IN
24	16X20[406X508]	16.8[426]	20.4[518]	1[25.4]	19.6	14.8
36	18X20[457X508]	18.3[466]	21.6[548]	1[25.4]	20.8	16.3
60/72	20X22[508X559]	20.7[526]	23.9[608]	1[25.4]	23	18.8

• AIR FILTER REMOVAL

- 1.Remove bolts manually, remove air filter recover, see in Fig 6;
2. Hold the edge of the air filter and extract out .
3. Clean the air filter (Vacuum cleaner or pure water may be used to clean the air filter. If the dust accumulation is too heavy, use soft brush and mild detergent to clean it and dry out in cool place) .

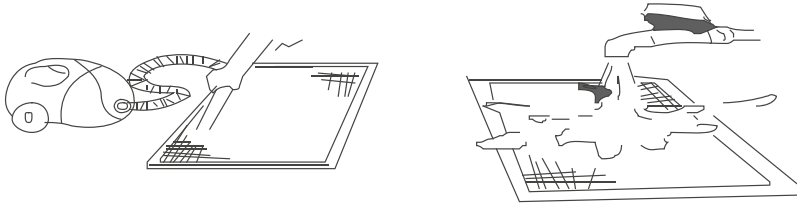

10. Wiring diagram

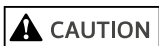

These units must be wired and installed in accordance with all National and Local Safety Codes. An all-pole disconnection device which has at least 3mm separation distance in all pole and a residual current device(RCD)with the rating of above 10mA shall be incorporated in the fixed wiring according to the national rule.

The appliance shall be installed in accordance with national wiring regulations.

1. To avoid the electrical shock, please connect the air conditioner with the ground lug. The main power plug in the air conditioner has been joined with the ground wiring, please don't change it freely.
2. The power socket is used as the air conditioner specially.
3. Don't pull the power wiring hard.
4. When connecting the air conditioner with the ground, observe the local codes.
5. If necessary, use the power fuse or the circuit, breaker or the corresponding scale ampere.

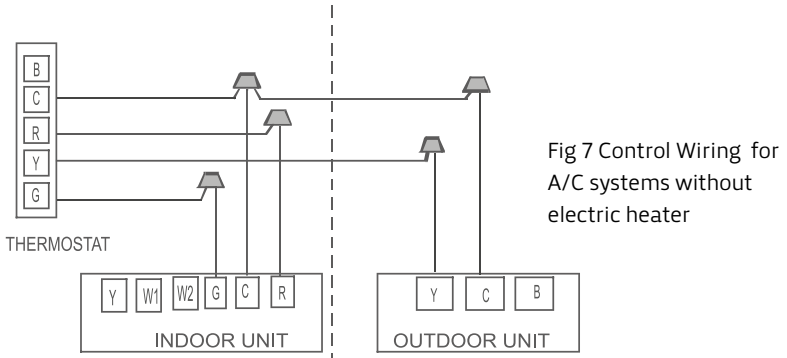

Suggestion

Thermostat choose KJR-23B or Non-programmed electrical thermostat series of Honeywell, such as TH 5220D. Wiring please refer to the Owner's Manual of the thermostat.

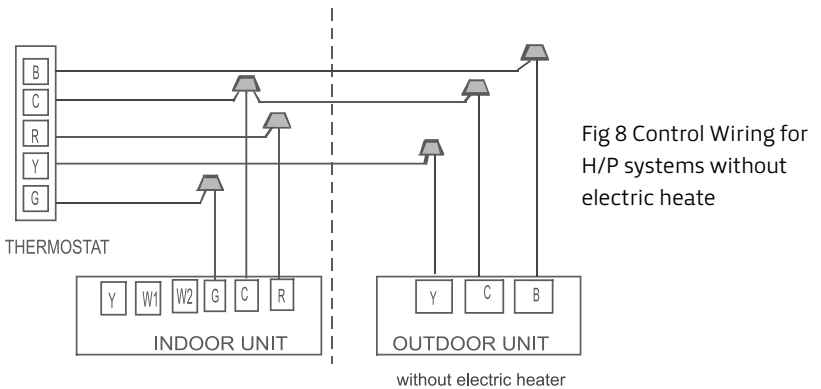

Suggestion

Thermostat choose KJR-25B or Non-programmed electrical thermostat series of Honeywell, such as TH 5220D. Broken lines means H/P system with electric heating. Wiring please refer to the Owner's Manual of the thermostat.

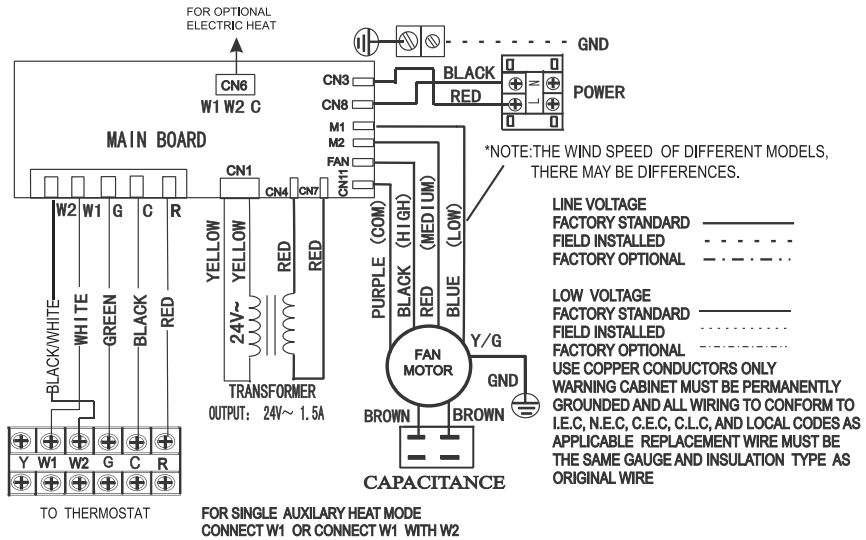

Fig 9 Indoor Unit Wiring Diagram for A/C systems and H/P systems.

Note: Description of fan speed switch

1. Different mode with different motor fan speed. For detail please refer to nameplate or actual model.
2. High speed wiring: Switch to high speed (black wire) and connect with FAN terminal, while medium speed (red wire) connect with M2 terminal.
3. Low speed wiring: Switch to low speed (blue wire) and connect with FAN terminal, while medium speed (red wire) connect with M1 terminal.

Fan speed	Terminal	FAN	M1	M2
Medium		Red	Blue	Black
High		Black	Blue	Red
Low		Blue	Red	Black

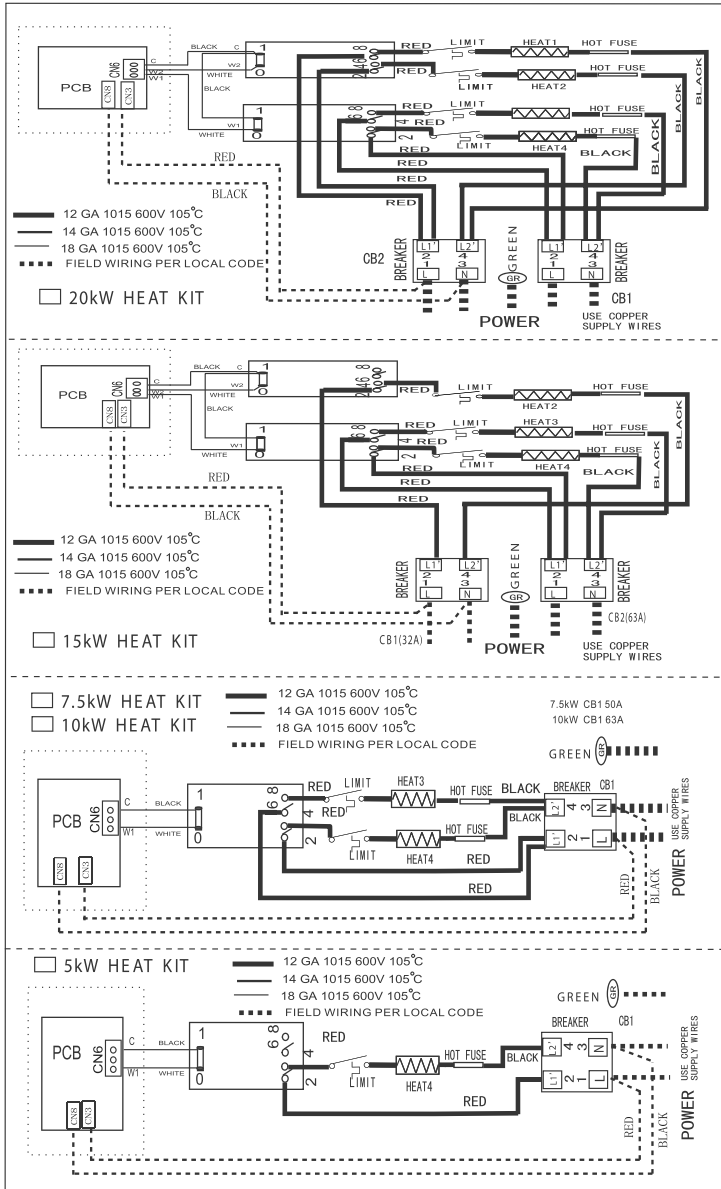

Fig 10 Indoor Unit Wiring Diagram for Electric Heat.

• ELECTRIC WIRING GAUGE

Wiring gauge for A/C systems

Model(Btu/h)		24	36	60	72	36/60/72 WITH 3-PHASE OUTDOOR UNIT	
Indoor Unit Power		Phase	Single				
		Voltage/frequency	220-240V, 50Hz				
Lines Gauge	Input Current Fuse	Indoor unit (A)	15A	15A	15A	15A	15A
		Line Quantity	3	3	3	3	3
	Input Current Fuse	Line Diameter(AWG)	14	14	14	14	14
		Line Quantity	3	3	3	3	5
	Input Current Fuse	Line Diameter(AWG)	14	12	10	10	14
		Line Quantity	2	2	2	2	2
	Input Current Fuse	Line Diameter(AWG)	18	18	18	18	18
		Line Quantity	4	4	4	4	4
Input Current Fuse	Line Diameter(AWG)	18	18	18	18	18	

Note: If indoor unit has auxiliary heating already installed and a different auxiliary heating unit is required the indoor unit (A) and indoor line diameters will be different.

Wiring gauge for H/P systems

Model(Btu/h)		24	36	60	72	36/60/72 WITH 3-PHASE OUTDOOR UNIT	
Indoor Unit Power		Phase	Single				
		Voltage/frequency	220-240V, 50Hz				
Lines Gauge	Input Current Fuse	Indoor unit (A)	15A	15A	15A	15A	15A
		Line Quantity	3	3	3	3	3
	Input Current Fuse	Line Diameter(AWG)	14	14	14	14	14
		Line Quantity	3	3	3	3	5
	Input Current Fuse	Line Diameter(AWG)	14	12	10	10	14
		Line Quantity	3	3	3	3	3
	Input Current Fuse	Line Diameter(AWG)	18	18	18	18	18
		Line Quantity	5	5	5	5	5
Input Current Fuse	Line Diameter(AWG)	18	18	18	18	18	

Note: If indoor unit has auxiliary heating already installed and a different auxiliary heating unit is required the indoor unit (A) and indoor line diameters will be different.

These units must be wired and installed in accordance with all National and Local Safety Codes.

Notas

Notas

BGH Eco Smart

OFICINA CENTRAL
Arias 1639 3° Piso
C.A.B.A. | C1429DWA
TEL (54 11) 4309-2000

www.ecosmart.bgh.com.ar



[ecosmart.bgh](https://www.facebook.com/ecosmart.bgh)



[ecosmart.bgh](https://www.instagram.com/ecosmart.bgh)



[BGH Eco Smart](https://www.linkedin.com/company/BGH-Eco-Smart)